

# L.E.S. Series HW "Scotch Box" Boilers

3-Pass Firetube • 30, 40, or 80 psi Water • 83% Efficiency • 4 sq.ft. Waterside Heating Surface per BHP

## Series HW RATINGS // DATA // DIMENSIONS

Model: HW-	580	800	950	1150	1450	1800	2070	2200	2650	3000	3350
<b>Input</b>											
Gas (MB/CF) CFH	695	960	1140	1385	1745	2165	2490	2650	3190	3610	4035
Oil (140MB/Gal) GPH	5.0	6.9	8.1	9.9	12.5	15.5	17.8	18.9	22.8	25.8	28.8
<b>Output</b>											
MBH	580	800	950	1150	1450	1800	2070	2200	2650	3000	3350
Boiler Horsepower	17	24	28	34	43	54	62	66	79	90	100
<b>Gas Burner Motor HP</b>	.25	.33	.33	.33	.5	.5	1.0	1.0	2.0	3.0	3.0
<b>Oil Burner Motor HP</b>	.33	.5	.5	.75	1.0	1.0	1.5	1.5	2.0	3.0	3.0
<b>Sq.Ft. Heating Surface</b>											
Primary	16.7	20.8	20.6	24.7	28.7	35.6	40.4	40.4	46.6	46.5	51.9
Total Fireside	61	85	101	125	154	199	234	234	285	324	358
Total Waterside	66	93	111	138	170	220	258	258	315	359	397
<b>Boiler Data</b>											
Furnace Vol. (Cu.Ft.)	4.5	6.1	6.1	7.7	9.3	13.6	15.8	15.8	20.3	20.3	23.2
Water Cap. (Gal; Full)	80	104	99	123	145	197	229	229	272	260	300
Dry Weight (LBS)	1250	1525	1600	1875	2175	2775	3175	3175	3700	4150	4275
<b>Dimensions in Inches</b>											
<b>A</b> Skid Length	29	39	39	49	59	59	68	68	68	68	78
<b>AA</b> Overall Length	70	80	80	90	100	102	112	112	114	114	124
<b>B</b> Width	28	28	28	28	28	34	34	34	34	34	34
<b>BB</b> Trimmed Width (Std)	30	30	30	30	30	36	36	36	36	36	36
<b>C</b> Height	58	58	58	58	58	64	64	64	72	72	72
<b>CC</b> Trimmed Height	64	64	64	64	64	71	71	71	80	80	80
<b>D</b> Rear Smokebox Depth	10	10	10	10	10	14	14	14	16	16	16
<b>F</b> Flue Connection Size	6	8	8	8	8	10	10	10	12	12	12
Flue Connection Height	48	48	48	48	48	56	56	56	62	62	62
<b>P</b> Burner Port Height	18	18	18	18	18	20	20	20	20	20	20
Burner Port ID	9¼	9¼	9¼	9¼	9¼	12¼	12¼	12¼	14½	14½	14½
<b>R</b> Return Size (NPT)	2	2	3	3	3	4	4	4	4	4	4
Return Height	8½	8½	8½	8½	8½	10½	10½	10½	10½	10½	10½
<b>S</b> Supply Size (*=Flange)	2	2	3	3	3	4*	4*	4*	4*	4*	4*
Supply Height	58	58	58	58	58	64	64	64	72	72	72

30 psi design pressure standard. 40 or 80 psi design available. Consult L.E.S. for high pressure weights.

Side View

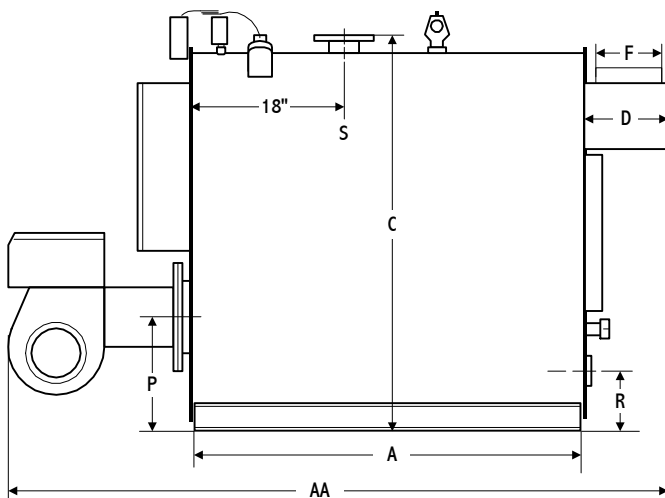

Front View

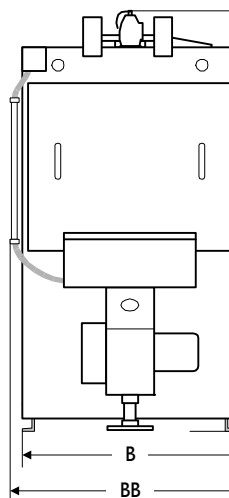

Rear View

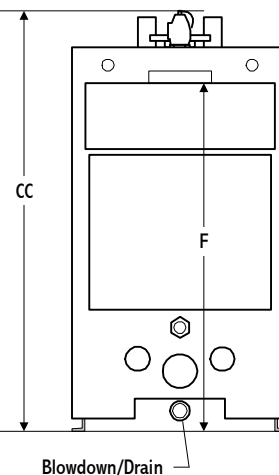

# L.E.S. Series HW3 "Scotch Box" Boilers

3-Pass Firetube • 30, 40, or 80 psi Water • 83% Efficiency • 4 sq.ft. Fireside Heating Surface per BHP

## Series HW3 RATINGS // DATA // DIMENSIONS

Model: HW3-	15	20	25	30	40	50	60	70	80	90
<b>Input</b>										
Gas (MB/CF) CFH	600	800	1000	1200	1610	2010	2410	2820	3220	3620
Oil (140MB/Gal) GPH	4.3	5.7	7.1	8.6	11.5	14.4	17.2	20.1	23.0	25.9
<b>Output</b>										
MBH	500	670	835	1000	1340	1675	2010	2345	2680	3015
Boiler Horsepower	15	20	25	30	40	50	60	70	80	90
<b>Gas Burner Motor HP</b>	.25	.33	.33	.33	.33	.5	1.0	1.0	2.0	3.0
<b>Oil Burner Motor HP</b>	.33	.33	.5	.5	.75	1.0	1.5	1.5	2.0	3.0
<b>Sq.Ft. Heating Surface</b>										
Primary	16.7	20.8	20.6	24.7	28.7	35.6	40.4	46.6	46.5	51.9
Total Fireside	61	85	101	125	154	199	234	285	324	358
Total Waterside	66	93	111	138	170	220	258	315	359	397
<b>Boiler Data</b>										
Furnace Vol. (Cu.Ft.)	4.5	6.1	6.1	7.7	9.3	13.6	15.8	20.3	20.3	23.2
Water Cap. (Gal; Full)	80	104	99	123	145	197	229	272	260	300
Dry Weight (LBS)	1250	1525	1600	1875	2175	2775	3175	3700	4150	4275
<b>Dimensions in Inches</b>										
<b>A</b> Skid Length	29	39	39	49	59	59	68	68	68	78
<b>AA</b> Overall Length	70	80	80	90	100	102	112	114	114	124
<b>B</b> Width	28	28	28	28	28	34	34	34	34	34
<b>BB</b> Trimmed Width (Std)	30	30	30	30	30	36	36	36	36	36
<b>C</b> Height	58	58	58	58	58	64	64	72	72	72
<b>CC</b> Trimmed Height	64	64	64	64	64	71	71	80	80	80
<b>D</b> Rear Smokebox Depth	10	10	10	10	10	14	14	16	16	16
<b>F</b> Flue Connection Size	6	8	8	8	8	10	10	12	12	12
Flue Connection Height	48	48	48	48	48	56	56	62	62	62
<b>P</b> Burner Port Height	18	18	18	18	18	20	20	20	20	20
Burner Port ID	9¼	9¼	9¼	9¼	9¼	12¼	12¼	14½	14½	14½
<b>R</b> Return Size (NPT)	2	2	3	3	3	4	4	4	4	4
Return Height	8½	8½	8½	8½	8½	10½	10½	10½	10½	10½
<b>S</b> Supply Size (*=Flange)	2	2	3	3	3	4*	4*	4*	4*	4*
Supply Height	58	58	58	58	58	64	64	72	72	72

30 psi design pressure standard. 40 or 80 psi design available. Consult L.E.S. for high pressure weights.

Side View

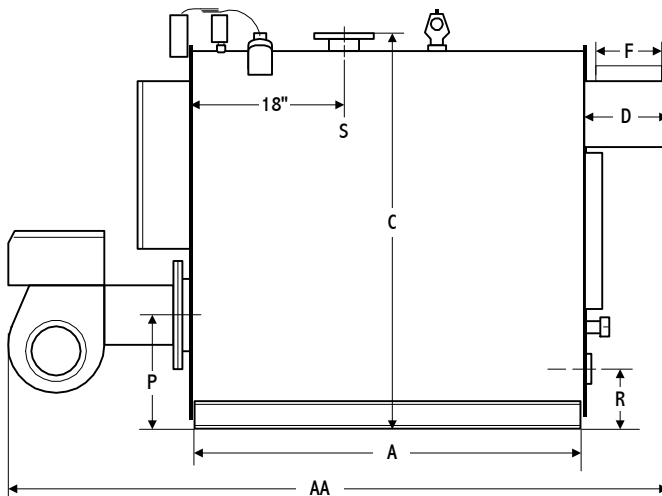

Front View

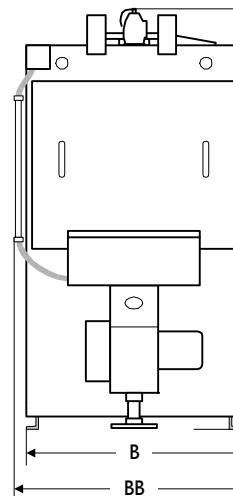

Rear View

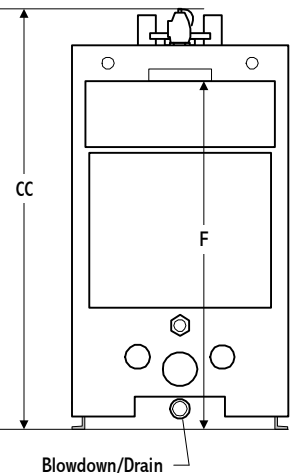

# L.E.S. Series HW5 "Scotch Box" Boilers

3-Pass Firetube • 30, 40, or 80 psi Water • 83% Efficiency • 5 sq.ft. Fireside Heating Surface per BHP

## Series HW5 RATINGS // DATA // DIMENSIONS

Model: HW5-	12	16	20	25	31	40	47	57	65	71
<b>Input</b>										
Gas (MB/CF) CFH	480	645	800	1000	1245	1610	1890	2290	2610	2850
Oil (140MB/Gal) GPH	3.4	4.6	5.7	7.1	8.9	11.5	13.5	16.4	18.6	20.4
<b>Output</b>										
MBH	400	535	670	835	1035	1340	1575	1905	2175	2375
Boiler Horsepower	12	16	20	25	31	40	47	57	65	71
<b>Gas Burner Motor HP</b>	.25	.25	.33	.33	.33	.33	.5	1.0	1.0	1.0
<b>Oil Burner Motor HP</b>	.33	.33	.33	.5	.5	.75	1.0	1.5	1.5	1.5
<b>Sq.Ft. Heating Surface</b>										
Primary	16.7	20.8	20.6	24.7	28.7	35.6	40.4	46.6	46.5	51.9
Total Fireside	61	85	101	125	154	199	234	285	324	358
Total Waterside	66	93	111	138	170	220	258	315	359	397
<b>Boiler Data</b>										
Furnace Vol. (Cu.Ft.)	4.5	6.1	6.1	7.7	9.3	13.6	15.8	20.3	20.3	23.2
Water Cap. (Gal; Full)	80	104	99	123	145	197	229	272	260	300
Dry Weight (LBS)	1250	1525	1600	1875	2175	2775	3175	3750	4150	4275
<b>Dimensions in Inches</b>										
<b>A</b> Skid Length	29	39	39	49	59	59	68	68	68	78
<b>AA</b> Overall Length	70	80	80	90	100	102	112	114	114	124
<b>B</b> Width	28	28	28	28	28	34	34	34	34	34
<b>BB</b> Trimmed Width (Std)	30	30	30	30	30	36	36	36	36	36
<b>C</b> Height	58	58	58	58	58	64	64	72	72	72
<b>CC</b> Trimmed Height	64	64	64	64	64	71	71	80	80	80
<b>D</b> Rear Smokebox Depth	10	10	10	10	10	14	14	16	16	16
<b>F</b> Flue Connection Size	6	8	8	8	8	10	10	12	12	12
Flue Connection Height	48	48	48	48	48	56	56	62	62	62
<b>P</b> Burner Port Height	18	18	18	18	18	20	20	20	20	20
Burner Port ID	9¼	9¼	9¼	9¼	9¼	12¼	12¼	14½	14½	14½
<b>R</b> Return Size (NPT)	2	2	3	3	3	4	4	4	4	4
Return Height	8½	8½	8½	8½	8½	10½	10½	10½	10½	10½
<b>S</b> Supply Size (*=Flange)	2	2	3	3	3	4*	4*	4*	4*	4*
Supply Height	58	58	58	58	58	64	64	72	72	72

30 psi design pressure standard. 40 or 80 psi design available. Consult L.E.S. for high pressure weights.

Side View

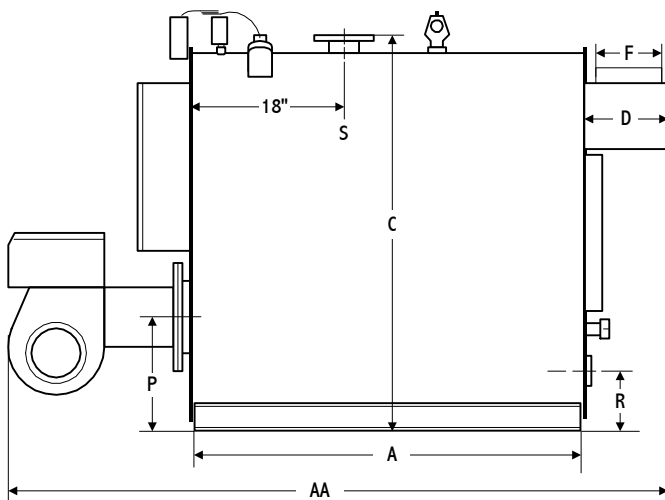

Front View

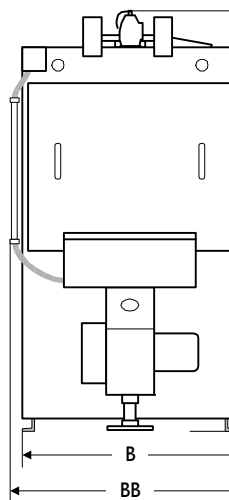

Rear View

